



# Elevated Stop Bar Light



**SBL**

Compliances: FAA AC 150/5345-46: L-862S

## Applications

The SBL fixture is used for runway incursion protection and traffic control on taxiways just before active runways. It is required for SMGCS operations during low visibility conditions as defined in FAA AC 150/5340-28 and AC 120-57A. This unidirectional light is designed for use in all weather conditions with any kind of control system including the Digitrac® Control and Monitoring System.

## Features



- ETL Certified L-862S
- Uses PK-30d low power consumption lamp
- Easy to install – mounts on a standard 2-inch (50 mm) mounting pipe with frangible coupling
- Mounting pipe extension included
- Easy to relamp – special tools are not required
- Cast aluminum housing
- Easy to aim
- Traffic signal red lens – eliminates need for separate filter
- Light head shipped fully assembled with lead assembly
- Control and Monitoring – Fixture can be supplied with a Crouse-Hinds Logitrac for individual lamp control and monitoring as required for flashing guard light operation or stop bar control. Contact Crouse-Hinds for more info

## Ordering Information

**How to Order:** To the basic catalog number, add the height. A breakable coupling is required for proper mounting and is supplied with the fixture. Order base plate separately.

**Example:** 862S-14 is a red stop bar light 14-inches high.

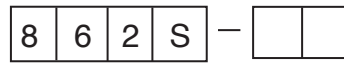

**Fixture Type:**

**Height, Inches:**

Standard Height 14 inches  
Available in 2-inch increments to 26 inches.

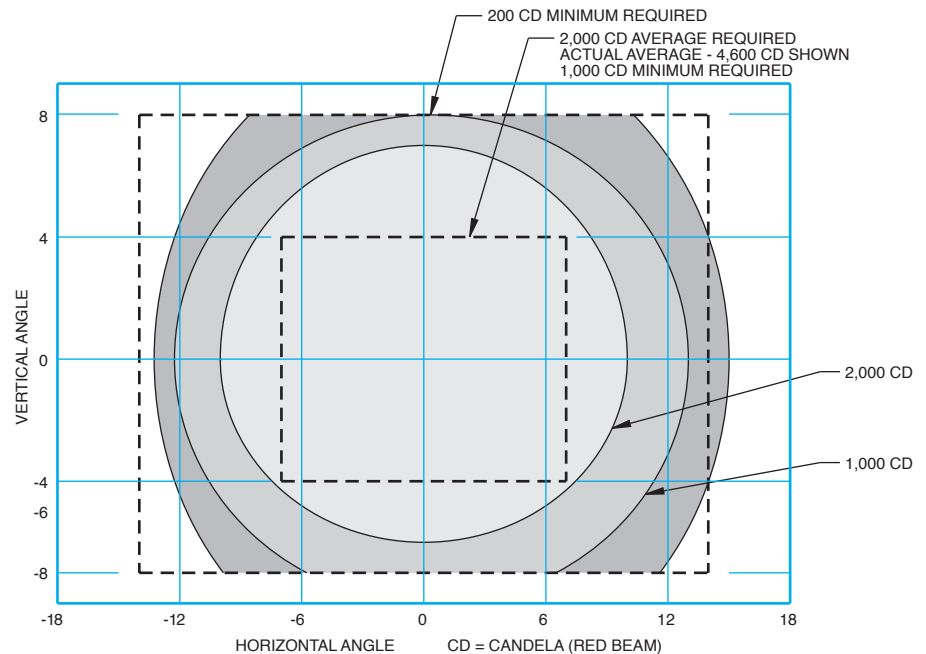

Typical photometric at 0° and 6.6 amps

## Outline Drawing

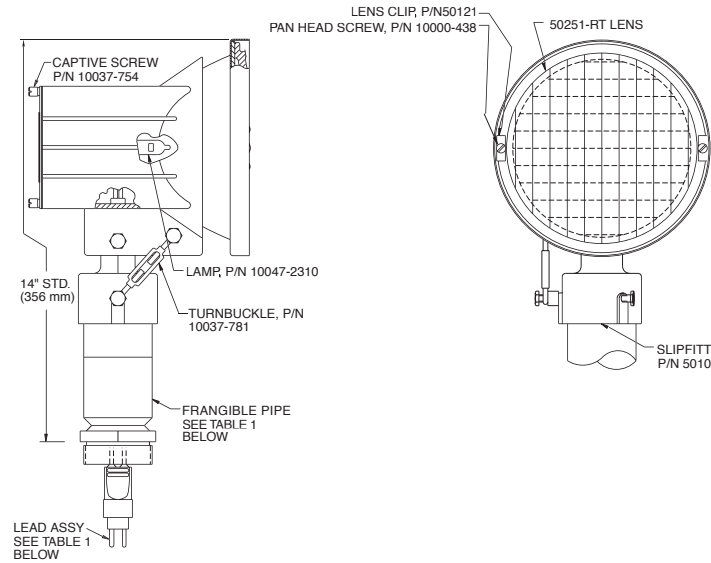

## Accessories

Part Number	Description	Shipping Weight		Shipping Volume	
		Lbs.	Kg	Cu.Ft.	Cu.M.
10047-2154	Heat Shrink Kit (1-piece)				
10047-1425	Heat Shrink Kit (2-piece)				
33006	Isolation Transformer 200 W, 6.6/6.6 A	8.9	4.04	0.3	0.009
33150	Isolation Transformer 150 W, 6.6/6.6 A	8.9	4.04	0.3	0.009
50133	Aiming Device (Optional)	2.0	0.91	0.13	0.004
823KP-D4-D4	Connector Kit L-823, 8 AWG, .32" to .43" O.D.				
AC21242H200301	Base L867, Class I, 24" Deep	52.0	23.6	2.6	0.074
AP1932	Baseplate, 2" Hub, 12" Diameter	8.0	3.6	0.14	0.004

## Renewal Parts

Part Number	Description	Part Number	Description
10A10-025D32	Bolt, Slipfitter Hex	10037-781	Turn Buckle
10000-438	Pan Head Screw	50121	Lens Clip
10047-754	Captive Screw	50251-RT	Lens, Traffic Signal Red
10047-2310	Lamp, PK-30d, 150 W, 6.6 A	50306 - X	Frangible Pipe Extension (See Table 1)
50106Y	Slipfitter, Less Hardware	50307 - X	Lead Assy., 6.6 A, (See Table 1)

**Table 1**

Height Inches (mm)	Frangible Pipe Part No.	Lead Assembly Part No.
14 (355.6)	50306-1	50307-1
16 (406.4)	50306-2	50307-2
18 (457.2)	50306-3	50307-3
20 (508.0)	50306-4	50307-4
22 (558.8)	50306-5	50307-5
24 (609.6)	50306-6	50307-6
26 (660.4)	50306-7	50307-7

<b>Instruction Sheet:</b>	9818
<b>Shipping Weight:</b>	6.7 lbs 3.04 kg
<b>Shipping Volume:</b>	0.80 cu.ft. 0.024 cu.m.

