

PRO III™ LHS



LHS

Land and Hold Short Light

Compliances: FAA AC 150/5345-46: L-850F

Applications

The LHS is a high intensity unidirectional light that uses two 48 watt lamps, one lamp as primary and one as back-up. This fixture is used as part of the Land and Hold Short system (LAHSO). The system consists of six L-850F lights, a power and control unit (PCU), and a tower control panel.

Features

- ETL Certified 
- Low profile, < .25" (6mm) – FAA Style 3
- Redundant lamp unit with automatic switch over to back-up lamp
- Low power consumption
- Few parts to stock
- Easy to maintain – no sealant required for prism or feed-through assembly replacement
- Pressure test plug for seal integrity verification
- Long Lamp Life – Quartz Halogen, 48 W, 6.6 A
- High-strength forged aluminum

Ordering Information

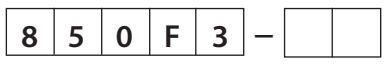

Fixture Type:

L-823 Plug Connection:

- *P1 = One plug
- **P2 = Two plugs

- * Unit is furnished with one plug, two lamps and film disc cutout for automatic switching to back-up lamp upon failure of primary lamp.
- ** Unit is furnished with two plugs and two lamps. Each lamp is powered by a different circuit (only one circuit energized at a time).

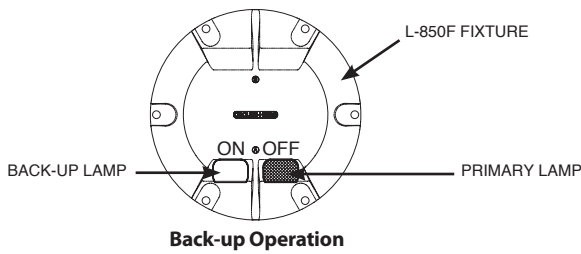
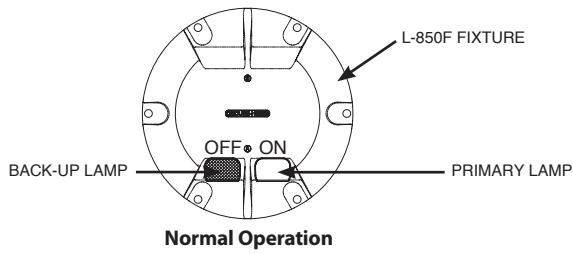

Outline Drawing

Dimensions:	inches (mm)
Instruction Manual:	9929
Shipping Weight:	16.0 lbs. 7.3 kg
Shipping Volume:	0.7 cu. ft. 0.02 m ³

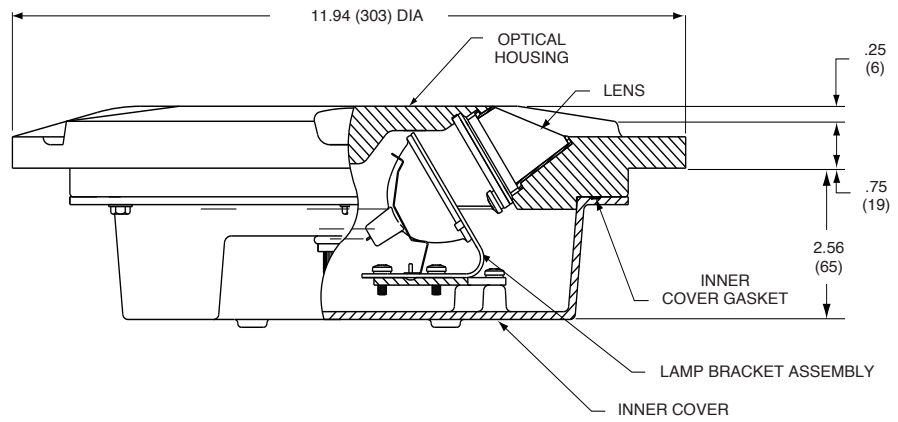

Typical Photometric Data

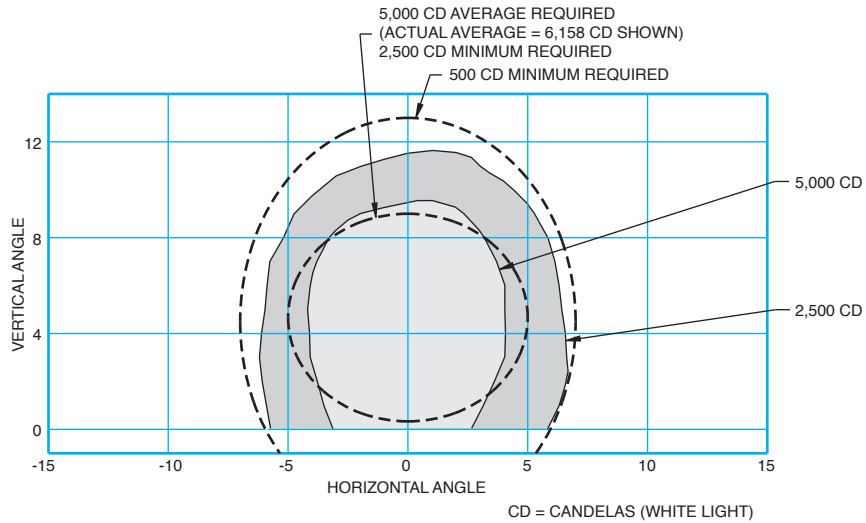

L-850F Land and Hold Short Light

Accessories

Catalog Number	Item Description	Catalog Number	Item Description
AC24242Q200303	Base: L-868B, Class I, 24" Deep	823KP-D4-D4	Connector Kit – L-823, 8 AWG, .32" to .43" O.D.
33001	Isolation Transformer – 45 W, 6.6/6.6 A	10047-2154	Heat Shrink Kit – 1 Piece
33002	Isolation Transformer – 45 W, 20/6.6 A	10047-1425	Heat Shrink Kit – 2 Piece
21238	Shallow Base – Aluminum	19999	Lifting Tool

Renewal Parts

Part Number	Description	Part Number	Description
21116	Lamp – 48 W, 6.6 A	21140	Gasket – Bottom Cover
21126-C	Lens Replacement Kit – Clear	21122	Feed-through Assembly – 1 Lamp, 1 Connector
10047-409	Film Disc Cutout	10048-25	Gasket Lubricant – 5.3 oz Container

Note:

1. Lens Replacement Kit includes lens, lens boot, lens retaining gasket, gasket lubricant, and lens retaining bracket and screws.

