

Approach Threshold Light

Compliances: FAA AC 150/5345-46: L-850E
ICAO Annex 14
USAF Regulation 88-14
USN NAVAIR 51-50AAA-2
NATO STANAG 3316

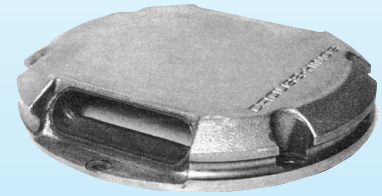

ATL

Applications

The ATL is a high intensity unidirectional inset runway threshold light. This light is typically used as a green threshold light with a 185 watt lamp. The main beam may be straight or toed-in 3.5 degrees toward the runway centerline. The ATL may be used as a red end of runway light and as a red stopbar light.

Features

- Proven reliability
- Variety of mounting methods
- Optional high strength casting approximately double the tensile strength of ductile iron
- Optional metallic-ceramic coating for increased corrosion resistance

Application Notes

- Sectional Class I bases may be required for proper installation.
- Size C ATL will also mount on a FAA-L867D base for special applications.
- Size B fixtures require that the bases be installed with any two opposite mounting bolt holes parallel to the runway centerline.

Ordering Information

How to Order: To the basic catalog number, add the letter to match the base size to be installed. Add designations for the lamp wattage and color. Complete the catalog number with a symbol to determine the optical beam toe-in.

Example: An 850E1-B-185-G-L is a unidirectional threshold light with left beam toe-in using a 185 watt lamp. It mounts on an 11.25-inch bolt circle base. There is one lead to plug into a 200 watt isolation transformer.

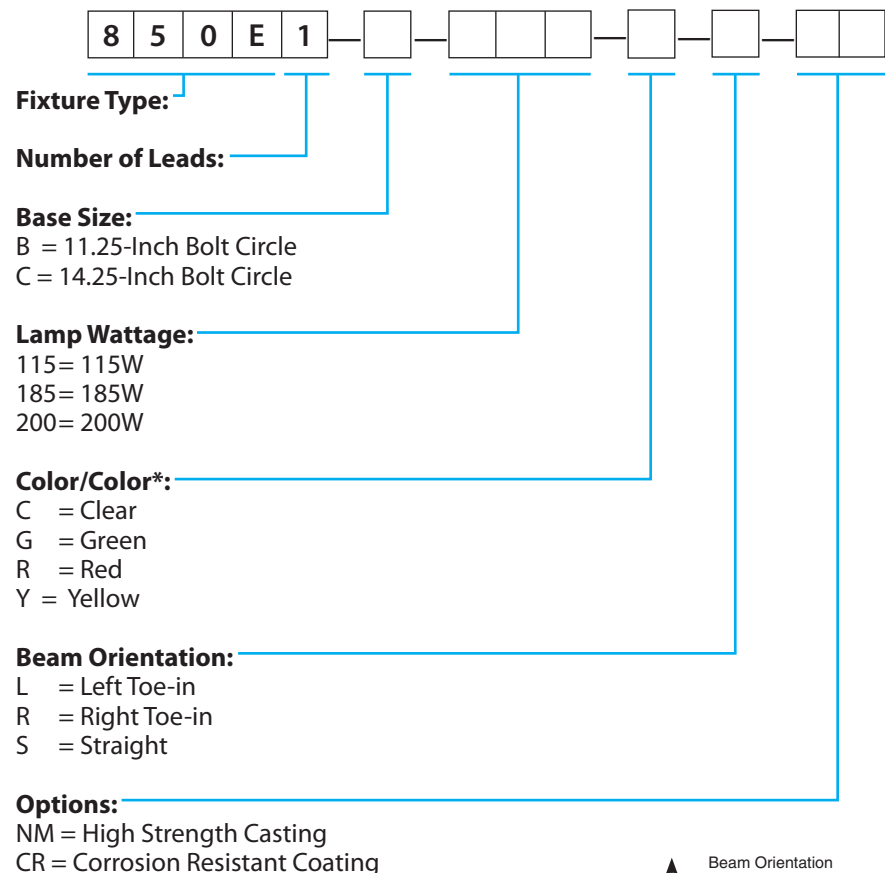

* Use 115 watts for VFR approaches only. Use 185 watts for all red lights and precision approaches.

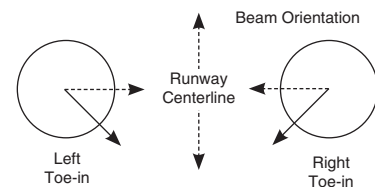

Installation Drawings

Dimensions:	inches (mm)	
Instruction Manual:	8401	
	Size B	Size C
Shipping Weight:	55.0 lbs. 25.0 kg	90.0 lbs. 41.0 kg
Shipping Volume:	0.75 cu.ft. .021 cu.	1.00 cu.ft. .032 cu.m.
Photometric Data:	Contact Field Services	

ATL-850E1-B

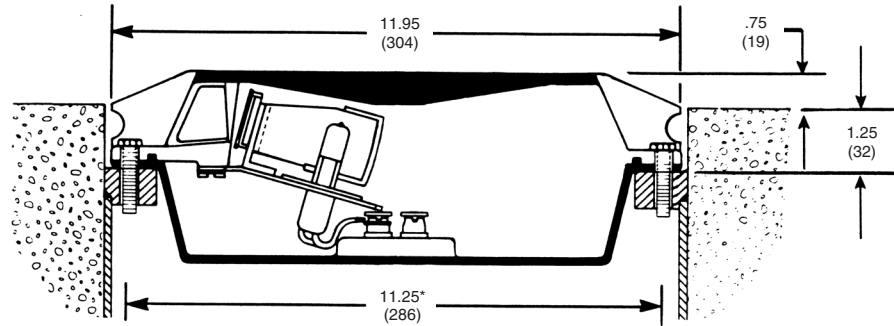

ATL-850E1-C

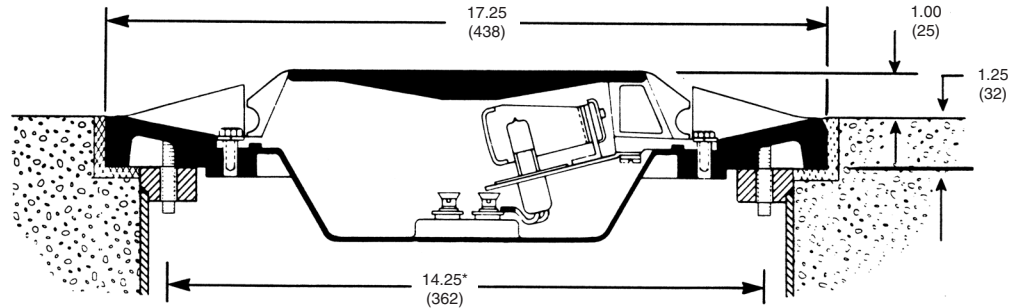

* Diameter for six (6) equally spaced bolts.

Accessories

Catalog Number	Item Description	Shipping Weight		Shipping Volume	
		Lbs.	Kg	Cu.Ft.	Cu.M.
AC24242Q200303	Base: L-868B, Class I, 24" Deep	63.0	28.6	2.5	.070
AC35242Q200303	Base: L-868C, Class I, 24" Deep	78.0	35.4	3.0	.085
AC63242Q200303	Base: L-867D, Class I, 24" Deep	67.0	30.4	4.3	.122
20452-S234	Base: Shallow, Size B	25.0	11.3	0.8	.022
33004	Transformer L-830-4, 100W 6.6/6.6A	12.0	5.4	0.4	.011
33006	Transformer L-830-6, 200W 6.6/6.6A	16.0	7.3	0.4	.011
33200	Transformer 200W 240V/30V for FAA MALS	16.0	7.3	0.4	.011
823KP-D4-D4	Connector Kit L-823, 8 AWG, .32" to 43" O.D.				
10047-1425	Heat Shrink Kit				

Renewal Parts

Part Number	Description	Part Number	Description
20496	Lamp 115W	19095-1	Socket
20538	Lamp 185W	19096	Socket Holder
20268	Lamp 200W	20462-2	Bottom Cover Assembly
20073-Y	Filter Assembly — Yellow	10047-409	Film Disc Cutout
20073-R	Filter Assembly — Red DICHROIC		
20073-G	Filter Assembly — Green DICHROIC		
20148	Reflector		
10035-33-274	O-Ring		
10035-33-010	O-Ring	20483-XXX-X-X*	Optical Assembly
21038	Lead Assembly	20481	Mounting ring

*Add lamp wattage, color, and beam orientation

