

AGS-2

Airside™ Guidance Sign



AGS-2

Compliances: FAA AC 150/5345-44: L-858
Unified Facilities Criteria UFC 3-535-01

Applications

Airside™ signs Model AGS are designed for use on airport taxiways to mark taxi routes and intersections. Colors may be black on yellow, yellow on black, or white on red depending on the application as defined by the governing standard FAA AC 150/5340-18. Black signs with white numerals are used to indicate distance remaining in thousands of feet of runway.

Features



- ETL Certified
- 62W Lamp
- Specification grade electrical system
- Power factor greater than 0.95 across all brightness steps
- Self-adjusting circuit board and internal transformer automatically maintains illumination level and uniformity across all steps (common for 3 or 5 step)
- Relamp without removing sign cover
- Modular design with uniform leg spacing
- One lamp per module
- Only one internal transformer per sign
- Slip-in sign faces without sealants
- Frangible couplings may be pre-installed on pad and sign lowered onto them for easy installation
- Available with fixed brightness (5.5A) for use on dedicated sign circuits
- Enclosed power entry through sign leg or
- Enclosed power entry through flexible liquidtight conduit (Option 11)
- External power disconnect switch breaks all electrical connections to the sign for safe maintenance (Option 12)
- Stainless steel tethers, two per sign except for one for single module. Single module additional tether available (option 20).
- High strength aluminum extrusion housing

Ordering Information

How to Order: To determine the number of modules to fit your message, contact Crouse-Hinds. For estimating purposes, use two characters per module. Do not count a 1 as a character except when the message contains an M or W. Maximum of four (4) modules per sign to comply with the FAA specification.**

Order isolation transformer, transformer housing, coverplate and gasket or baseplate, and connector kit separately. The colors of the sign faces and the legends must be specified for each sign. Multiple messages and colors may appear on a sign face.

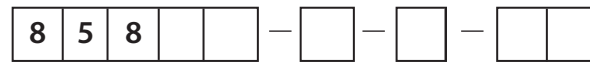

Fixture Type:

FAA Size:

- 1 = Taxiway Sign, 30" High
- 2 = Taxiway Sign, 36" High
- 3 = Taxiway Sign, 42" High
- 4 = Distance Marker, 60" High***
- 5 = Distance Marker, 42" High

Number of Faces:

- 1 = Single Face
- 2 = Double Face

Brightness Levels:

- 1 = FAA Class 1 & 2, Style 5 (Fixed, 5.5A)*
- 3 = FAA Class 1 & 2, Style 2 (3 Steps, 4.8 to 6.6A)
- 5 = FAA Class 1 & 2, Style 3 (5 Steps, 2.8 to 6.6A)

Number of Lamp Modules: 1 to 4

Options:

- 10 = Unenclosed Power Cable: 3 Ft. with Plug
- 11 = Flexible Liquidtight Conduit Enclosed 3 Ft. Power Cable
- 12 = External Power Switch
- 19 = Lamp Out Indicator (Not available on brightness level option 1 signs (Fixed, 5.5a))
- 20 = Additional Tether (Single module sign only)

* Use 33101, 33102 or 33103 isolation transformers only. Resistive load only. Use step 2 of a 3-step regulator.

** 4 Module size 2 exceeds specifications by 0.6 inches.

*** Size 4 Distance Marker provides 2 lamp modules—transformer to be sized accordingly.

Technical Data

Airside™ Guidance Signs (AGS)

Measured Load (VA) & Power Factor (PF)

Lamp Modules	Isolation Transformer	CCR	VA*	PF (min)
1	100W	5-Step	100	0.95
	100W	3-Step	100	0.95
2**	200W	5-Step	160	0.95
	200W	3-Step	160	0.95
3	300W	5-Step	230	0.95
	300W	3-Step	230	0.95
4	300W*	5-Step	290	0.95
	300W*	3-Step	290	0.95

* Applies to all FAA sizes, single and double face. Measured wattage exceeds the total of the lamp wattages due to the power consumption of the sign's internal electrical system, and isolation transformer.

** Includes FAA Size 4 distance marker sign.

Dimensional Information

Floor Flange 25684-1

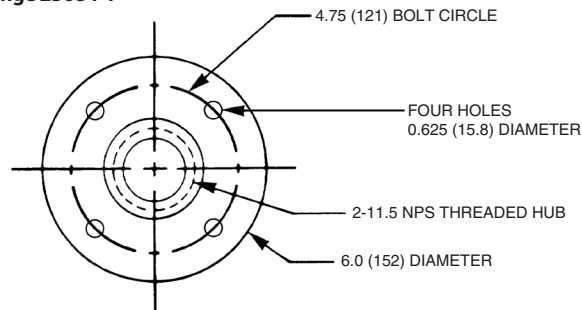

Dimensions: inches (mm)

Shipping Weights and Volumes

		Modules							
		1		2		3		4	
		lbs. (kg.)	cu.ft. (cu.m.)	lbs. (kg.)	cu.ft. (cu.m.)	lbs. (kg.)	cu.ft. (cu.m.)	lbs. (kg.)	cu.ft. (cu.m.)
Size	1	65 (29.5)	5.7 (0.16)	130 (59.0)	11.4 (0.32)	195 (88.5)	17.1 (0.48)	260 (118)	22.8 (0.65)
	2	90 (40.8)	8.5 (0.24)	180 (81.6)	17.0 (0.48)	270 (122.5)	25.5 (0.72)	360 (163.3)	34.0 (0.96)
	3 & 5	115 (52.2)	11.3 (0.32)	230 (104.3)	22.6 (0.64)	345 (156.5)	34.0 (0.96)	460 (208.7)	45.3 (1.28)
	4	145 (65.8)	26.5 (0.75)	—	—	—	—	—	—



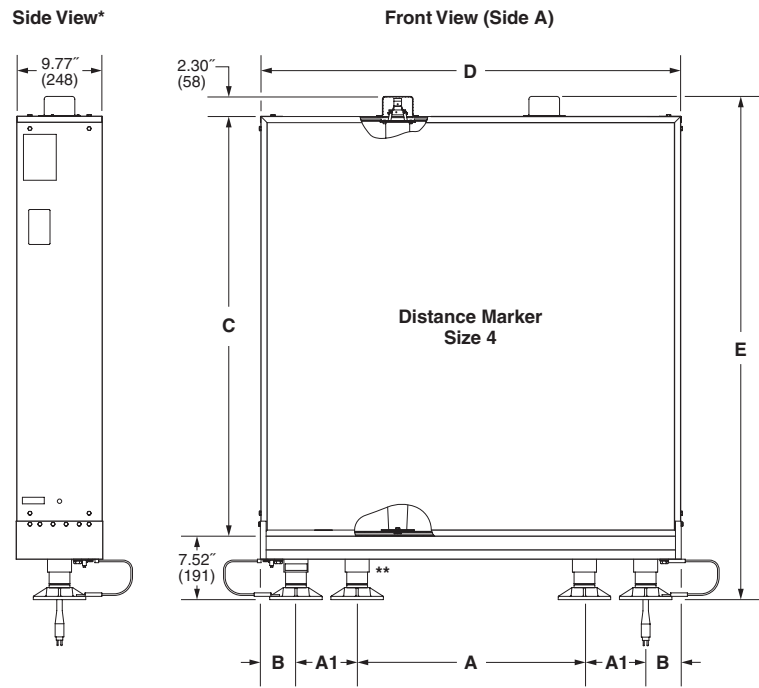
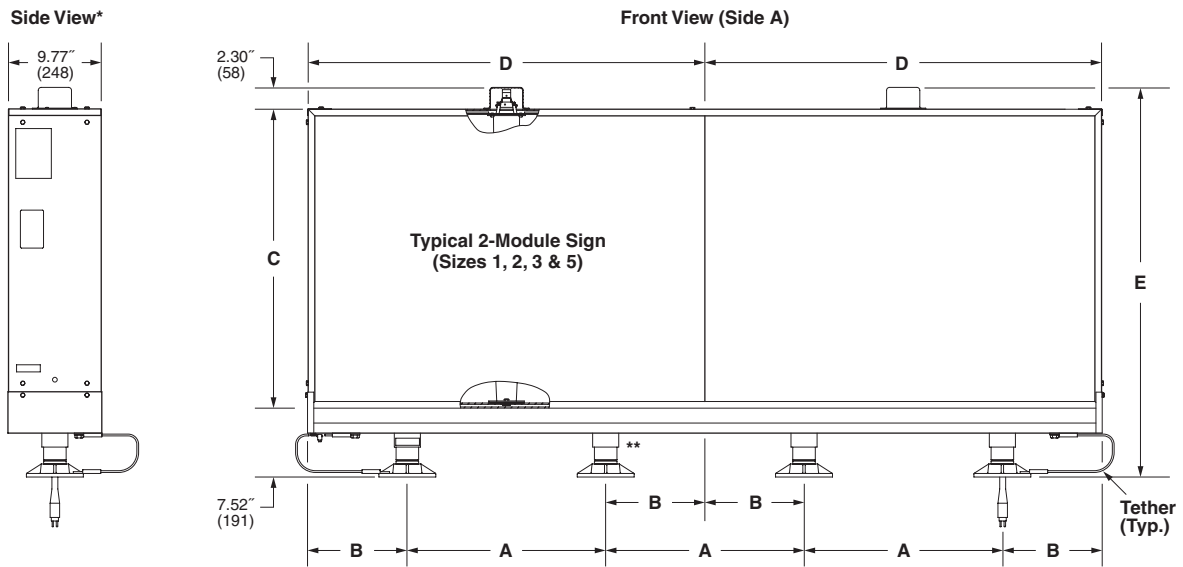

Sign Power Leg Orientation
 When facing side A, the power entry is on the right. Orders should always specify the message orientation.

- * Typical for all signs.
- ** The sign includes floor flanges for all legs. Installation may vary: See the manual.

Dimensions:	inches	
	(mm)	
Instruction Manual:	9211	Size 1,2,3,5
	9213	4

		Dimensions					
		A	A1	B	C	D	E
Size	1	14.60 (371)	—	7.30 (185)	19.50 (495)	29.20 (742)	29.05 (738)
	2**	18.20 (462)	—	9.10 (231)	25.50 (648)	36.40 (925)	35.05 (891)
	3 & 5	20.90 (531)	—	10.45 (265)	31.50 (800)	41.80 (1062)	41.05 (1043)
	4	26.00 (660)	7.00 (178)	4.00 (102)	48.00 (1219)	48.00 (1219)	57.55 (1462)

** 4 module size 2 exceeds specifications by 0.6 inches.

Installation Details

Elbow Mounting Detail

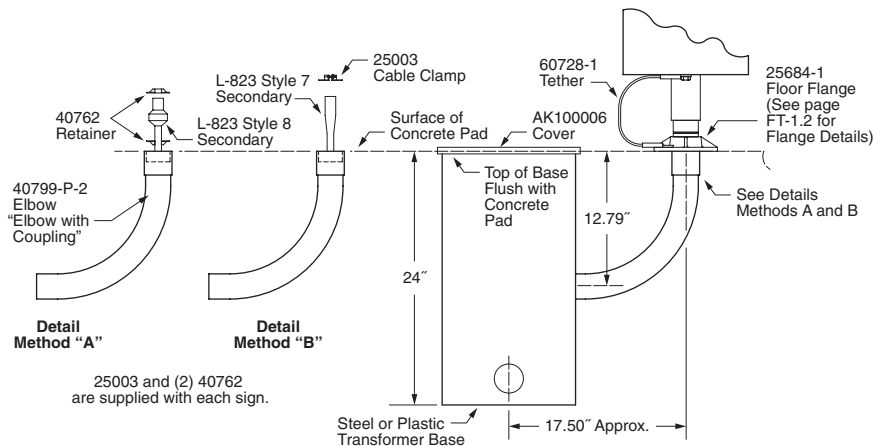

Steel Base Mounting Detail Sizes 1, 2, 3, & 5

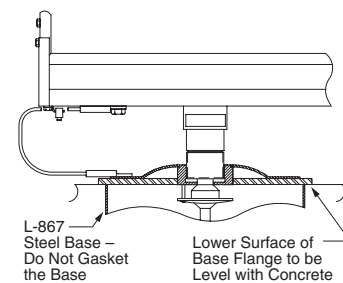

Accessories

Part Number	Description	Shipping Weight		Shipping Volume	
		Lbs.	Kg.	Cu.Ft.	Cu.M.
33004	Isolation Transformer 100 watts, 6.6/6.6A	12.0	5.4	0.4	0.011
33101	Isolation Transformer 100 watts, Style 5 (fixed brightness) 5.5/6.2A	12.0	5.4	0.4	0.011
33006	Isolation Transformer 200 watts, 6.6/6.6A	16.0	7.3	0.4	0.011
33102	Isolation Transformer 200 watts, Style 5 (fixed brightness) 5.5/6.2A	16.0	7.3	0.4	0.011
33103	Isolation Transformer 300 watts, (fixed brightness) 5.5/6.2A	16.0	7.3	0.4	0.011
33010	Isolation Transformer 300 watts, 6.6/6.6A	23.0	10.4	0.6	0.017
AP1932*	Baseplate, 2 inch Hub	8.0	3.6	0.14	0.004
AC21242HX00301*	Base L-867, Class 1, 24 inches deep	52.0	23.6	2.6	0.074
AK100006	Coverplate, 0.375 inches thick	5.0	2.3	0.13	0.004
900152*	Base L-867, Class II (PLASTIC), 24 inches deep	16.0	7.3	2.6	0.074
10530287	Gasket for Coverplate				
823KP-D4-D4	Primary L-823 Connector Kit				
26811-27	Consolidating Harness				
CAS1M-PR-B-2	Secondary Cable Assembly, 2 meters**				

* If the power leg is baseplate mounted directly on a base, only the AC21242HX00301 may be used with no gasket for the baseplate AP1932 to insure equal breakaway with the other legs. The base must be installed per the instruction manual, approximately 3/8 inch high with the lower edge of the base top flange level with the concrete. If the sign power leg is elbow mounted, base 900152 has conduit entries in the required positions.

** Other lengths available. The sign includes cable clamp 25003 and two 40762 retainers.

Renewal Parts

Part Number	Description	Part Number	Description
20590	Lamp 62 watts, 6.6A	61143	Internal Transformer
25684-1	Floor Flange	60638	Lamp Cover Cap
62245-1	Frangible Coupling: Size 1	60685-X**	Light Tube Assembly
62245-2	Frangible Coupling: Size 2	61107	Lamp Socket
62245-3	Frangible Coupling: Size 3	61107	Lamp Socket
62245-5	Frangible Coupling: Size 5	61107	Lamp Socket
62245-4	Frangible Coupling: Size 4	60639	Lamp Cover Cap Gasket
CAS1M-P-B-86	Lead Assembly	60728-1	Tether
61153-1***	Circuit Board: 3-step, 5-step		
60667*	Sign Face, Retroreflective		
60668*	Blank Panel		

* Dash number required for size and number of modules (contact factory). Add description of color and legend.

** Insert dash number 1 or 2 or 3 for sign size 1 or 2 or 3 accordingly.

*** Only compatible with 61143 internal transformer.

